



## VMS 80 METERING LOADING DEVICE

**VMS 80** is a vacuum, conveying system for dosing boneless meat.

**VMS 80** can be connected to Tumblers, tanks etc. to load machines, work tables. The potential is huge.

**VMS 80** is fully automatic and easily adjusted to its task and to keep in step with other machines in a product line.

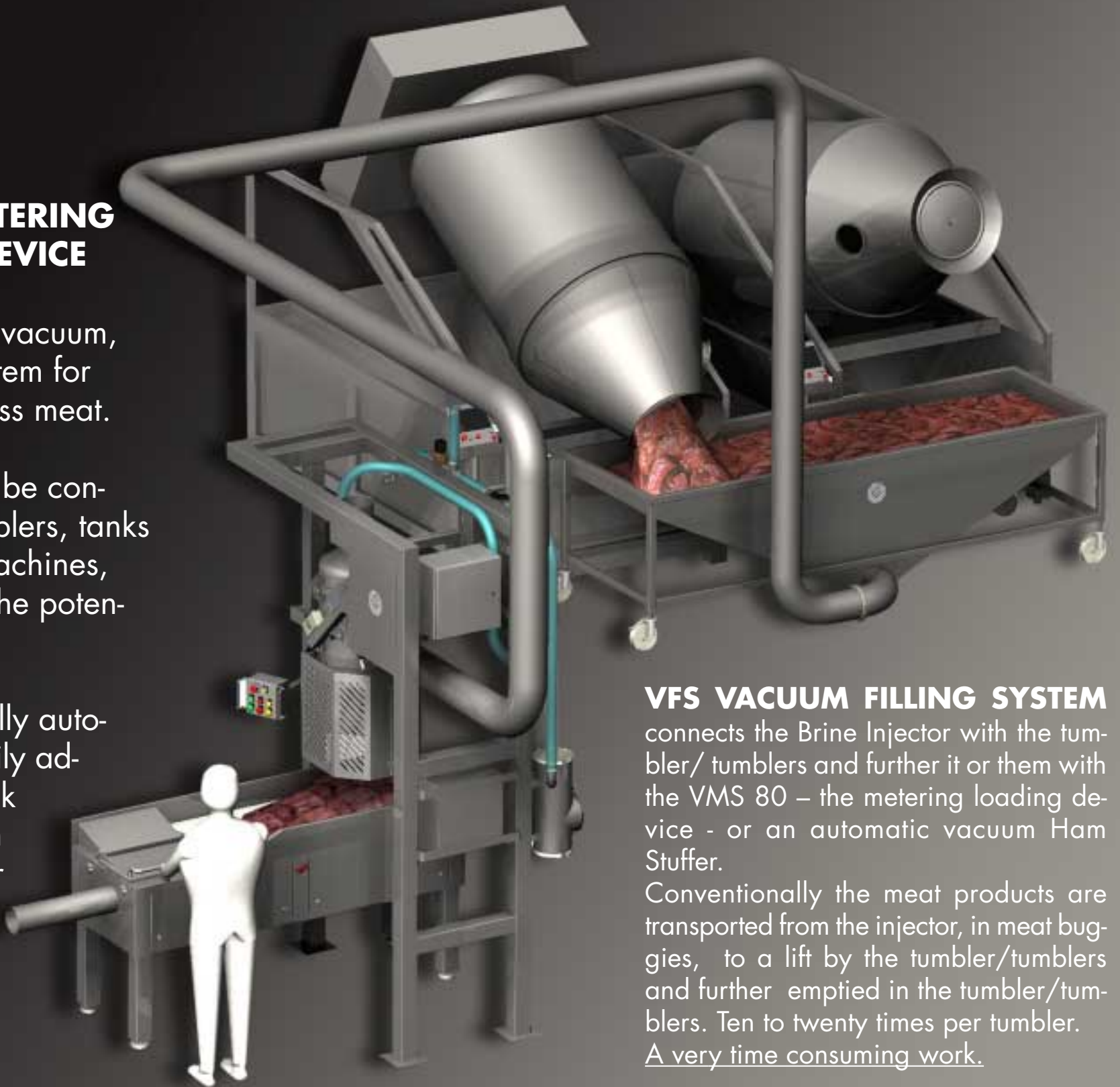

## VFS VACUUM FILLING SYSTEM

connects the Brine Injector with the tumbler/ tumblers and further it or them with the VMS 80 – the metering loading device - or an automatic vacuum Ham Stuffer.

Conventionally the meat products are transported from the injector, in meat buggies, to a lift by the tumbler/tumblers and further emptied in the tumbler/tumblers. Ten to twenty times per tumbler. A very time consuming work.

Up to 80% from the labor work can be saved with our system.



## BRINE INJECTOR/TENDERISER GSI 160/576

for bone in or boneless meat. —The Tenderiser only boneless - 160 PCS single needles. Every needle has its own valve. The needle bridge has no springs and no hoses (Only the indispensable one from the pump to the needle bridge.) The machine room is also free of hoses. Fully automatic central lubrication system. Four color touch screen panel including programmable control of all process parameters. The system also includes recommended maintenance. The Tenderiser has 576 PCS knives (1,25 x 6 mm). The tenderise bridge can easily disconnected.



## GH107 BRINE/MARINADE MIXER

The best in the world?  
Though there are similar looking brine mixers, we say that the Garos brine preparation system is the most complete and capable system — specially designed to handle the more frequently presence of large quantities of dry ingredients



## GAROS MDF MASSAGERS/TUMBLERS

are available in several standard sizes. Up to 65% of the volume can be loaded due to the tilting drum, which also simplifies the emptying considerably together with the large hydraulic cover. As the name MDF hints the GAROS Tumblers are built with a uniquely designed set of asymmetrical carriers to obtain optimum of product movement, e.g., more effective massaging. Maintenance extraordinary easy accessible. Cooling jacket is general standard. Load cells and weight indicator are available.

The GAROS "VFS — Vacuum Filling System" is a fully automatic and integrated system for loading boneless products into the massager, without any manual handling.

With VFS connected to the massager, the products are sucked straight from the injector into the massager, at the same pace as the injector. It eliminates vats, product traffic flow, and reduces human handling.

90% of the massagers delivered in our native Scandinavia are equipped with VFS. We supply small systems for a few massagers up to large systems for several machines. The VFS system can also be gradually extended, as the massaging capacity is increased with new massagers. Even transport from the massager to a pump/stuffer could be done with a VFS. The system is equipped with a specially developed cleaning unit.

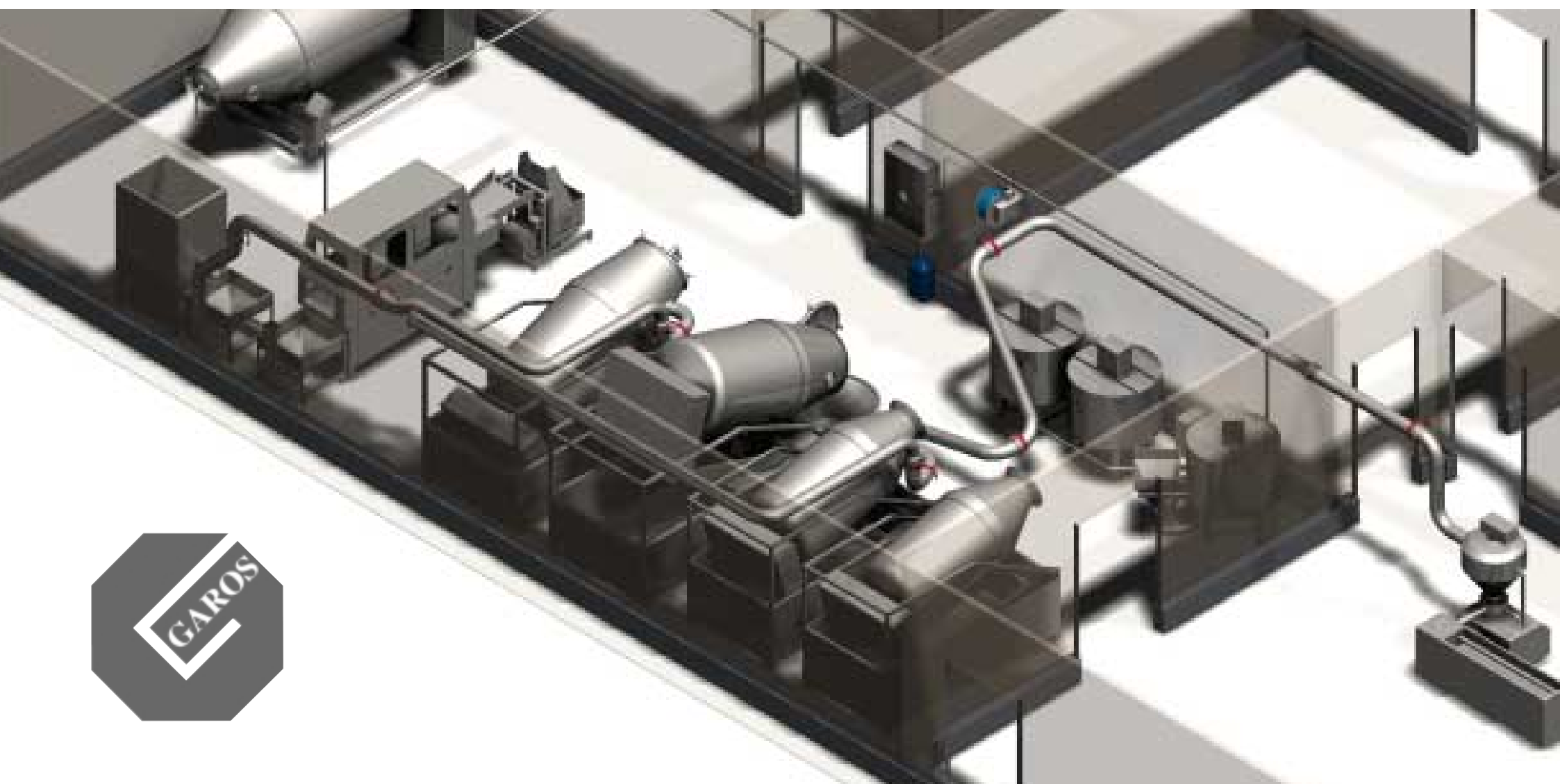
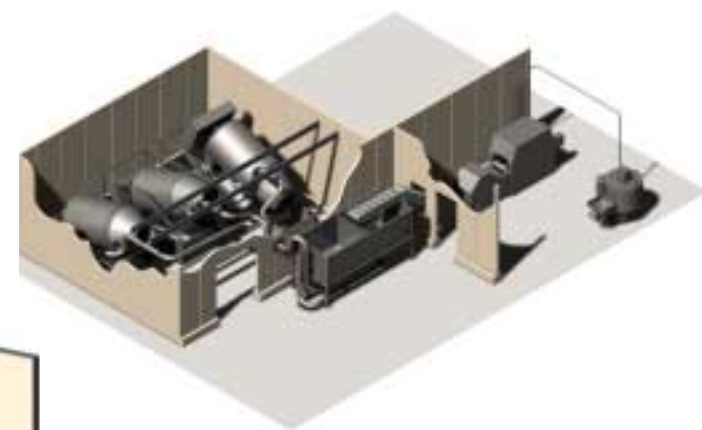
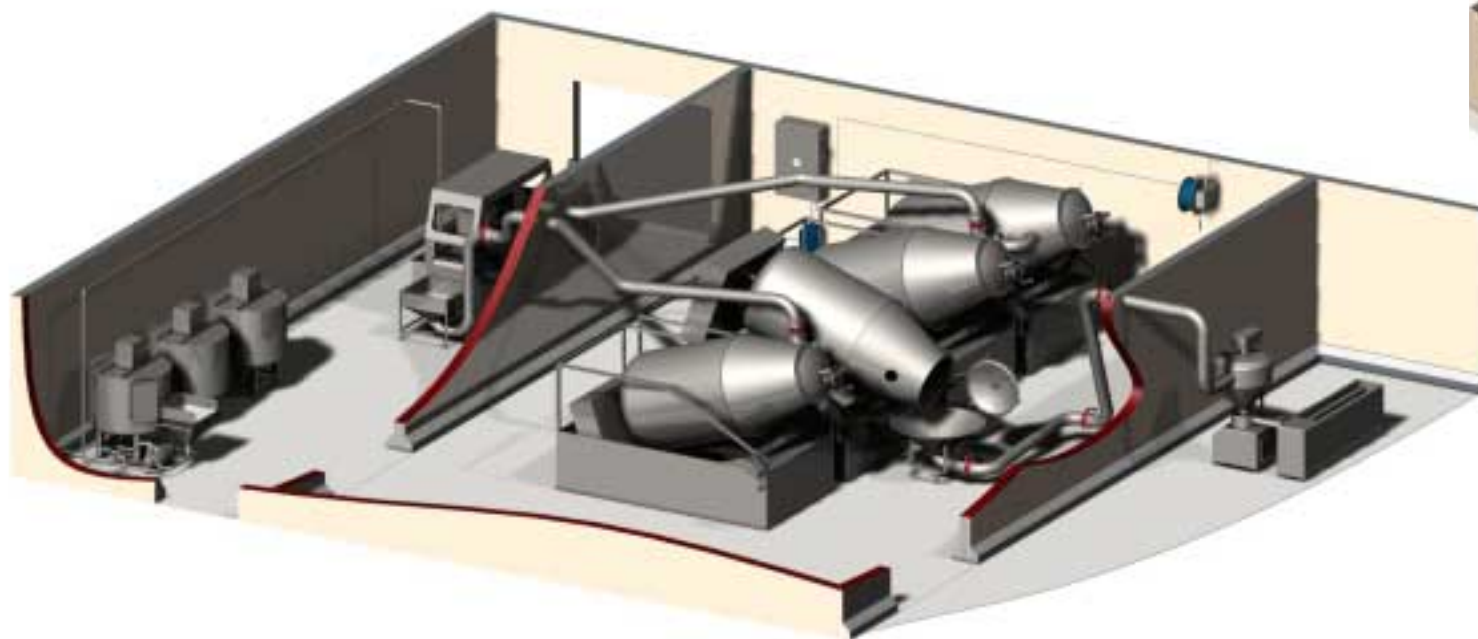

AB GAROS  
Box 343  
SE-551 15 JÖNKÖPING  
Phone: +46 36 181130  
Fax: +46 36 181140  
E-mail: [garos@garos.se](mailto:garos@garos.se)  
[www.garos.net](http://www.garos.net)